



BYBU.XR621 - Fire-resistance Ratings - ANSI/UL 1709

Design/System/Construction/Assembly Usage Disclaimer

- Authorities Having Jurisdiction should be consulted in all cases as to the particular requirements covering the installation and use of UL Certified products, equipment, system, devices, and materials.
- Authorities Having Jurisdiction should be consulted before construction.
- Fire resistance assemblies and products are developed by the design submitter and have been investigated by UL for compliance with applicable requirements. The published information cannot always address every construction nuance encountered in the field.
- When field issues arise, it is recommended the first contact for assistance be the technical service staff provided by the product manufacturer noted for the design. Users of fire resistance assemblies are advised to consult the general Guide Information for each product category and each group of assemblies. The Guide Information includes specifics concerning alternate materials and alternate methods of construction.
- Only products which bear UL's Mark are considered Certified.

BYBU - Fire-resistance Ratings - ANSI/UL 1709

[See General Information for Fire-resistance Ratings - ANSI/UL 1709](#)

Design No. XR621

October 03, 2019

Rating - 3 Hr

*** Indicates such products shall bear the UL or cUL Certification Mark for jurisdictions employing the UL or cUL Certification (such as Canada), respectively.**

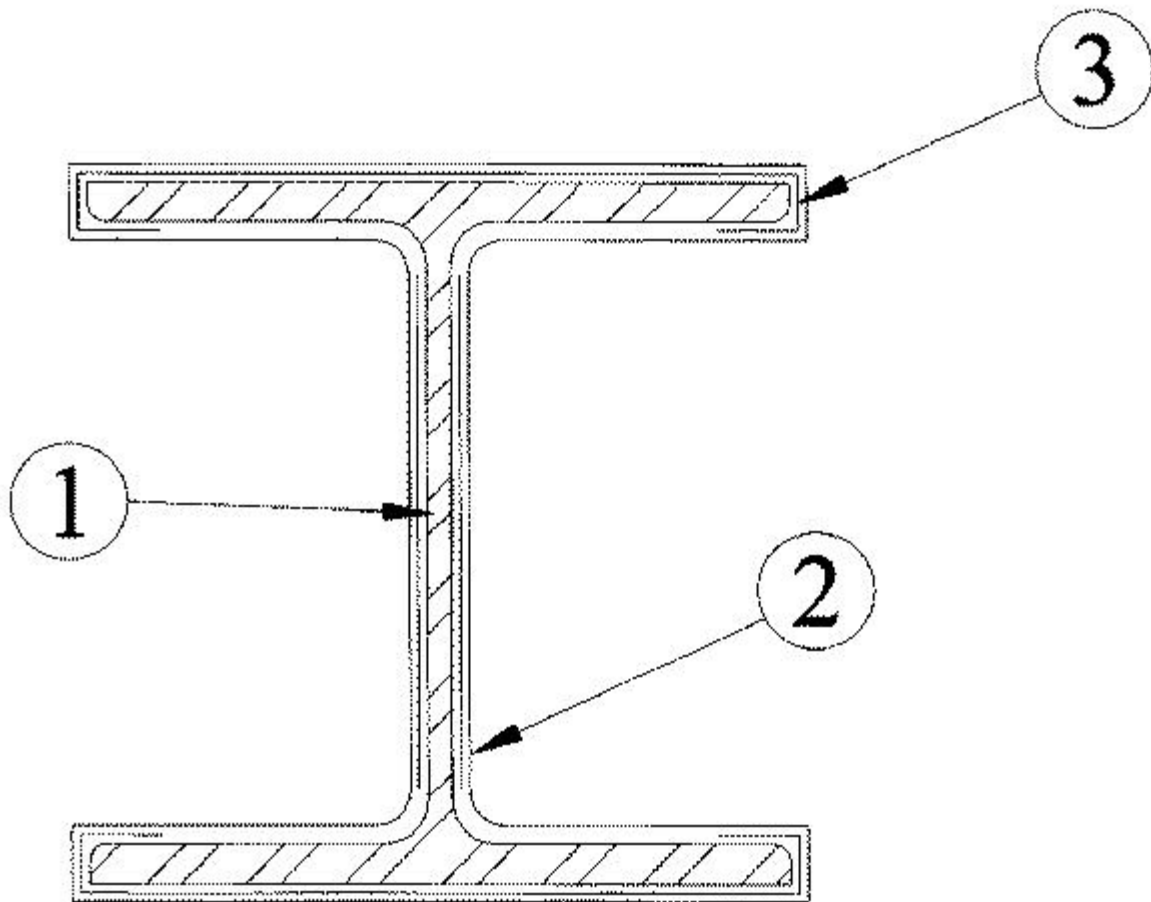

1. **Steel Column** — W14 x 342 wide flange steel column.

2. **Mastic and Intumescent Coating** — Spray applied in one or more coats to the required thickness. Column surfaces which must be free of dirt, loose scale and oil. Column surfaces to be primed. Primer thickness approximately 0.0015 in. Coating lightly rolled after final coat with a paint roller. Coating applied in accordance with manufacturer's instruction to a min thickness of 0.29 in.

CARBOLINE CO — Types Thermo-lag 3000-SP, Thermo-Lag 3000-P, Thermo-Lag 3000-SA, Thermo-Lag 3000-A and Thermo-Lag 3000-FC INVESTIGATED FOR UL 2431 CLASSIFICATION CATEGORY I- A and EXTERIOR ENVIRONMENTAL PURPOSE.

3. **Carbon Fiber Mesh** — Nom 3/16 in. by 3/16 in. 3.50 oz/sq yd carbon fiber mesh to cover the entire flange face, flange tips, and 1/2 the depth of the inner flange. The flange mesh shall be applied in a horizontal orientation with adjacent horizontal pieces of mesh overlapped a minimum of 1 in. The mesh shall be applied to the web in a vertical orientation and shall span the width and length of the web. The reinforcing mesh shall be imbedded in the mastic and intumescent coating (Item 2) at a depth of approximately 0.12 in.

4. **Top Coat*** — Type Carbomastic 94 MC topcoat applied over mastic and intumescent coating (Item 2) at 0.005 to 0.012 in. thicknesses.

*** Indicates such products shall bear the UL or cUL Certification Mark for jurisdictions employing the UL or cUL Certification (such as Canada), respectively.**

Last Updated on 2019-10-03

The appearance of a company's name or product in this database does not in itself assure that products so identified have been manufactured under UL's Follow-Up Service. Only those products bearing the UL Mark should be considered to be Certified and covered under UL's Follow-Up Service. Always look for the Mark on the product.

UL permits the reproduction of the material contained in the Online Certification Directory subject to the following conditions: 1. The Guide Information, Assemblies, Constructions, Designs, Systems, and/or Certifications (files) must be presented in their entirety and in a non-misleading manner, without any manipulation of the data (or drawings). 2. The statement "Reprinted from the Online Certifications Directory with permission from UL" must appear adjacent to the extracted material. In addition, the reprinted material must include a copyright notice in the following format: "© 2021 UL LLC"