



BXUV.D946

Design/System/Construction/Assembly Usage Disclaimer

- Authorities Having Jurisdiction should be consulted in all cases as to the particular requirements covering the installation and use of UL Certified products, equipment, system, devices, and materials.
- Authorities Having Jurisdiction should be consulted before construction.
- Fire resistance assemblies and products are developed by the design submitter and have been investigated by UL for compliance with applicable requirements. The published information cannot always address every construction nuance encountered in the field.
- When field issues arise, it is recommended the first contact for assistance be the technical service staff provided by the product manufacturer noted for the design. Users of fire resistance assemblies are advised to consult the general Guide Information for each product category and each group of assemblies. The Guide Information includes specifics concerning alternate materials and alternate methods of construction.
- Only products which bear UL's Mark are considered Certified.

BXUV - Fire Resistance Ratings - ANSI/UL 263 Certified for
United States

BXUV7 - Fire Resistance Ratings - CAN/ULC-S101 Certified for
Canada

See General Information for Fire-resistance Ratings - ANSI/UL 263 Certified for United States
Design Criteria and Allowable Variances

See General Information for Fire Resistance Ratings - CAN/ULC-S101 Certified for Canada
Design Criteria and Allowable Variances

Design No. D946

August 27, 2019

Restrained Assembly Rating - 2 Hr. (See Items 2, 5 and 7)

Unrestrained Beam Rating - 1 Hr. (See Items 2, 5 and 7)

This design was evaluated using a load design method other than the Limit States Design Method (e.g., Working Stress Design Method). For jurisdictions employing the Limit States Design Method, such as Canada, a load restriction factor shall be used — See Guide BXUV or BXUV7

*** Indicates such products shall bear the UL or cUL Certification Mark for jurisdictions employing the UL or cUL Certification (such as Canada), respectively.**

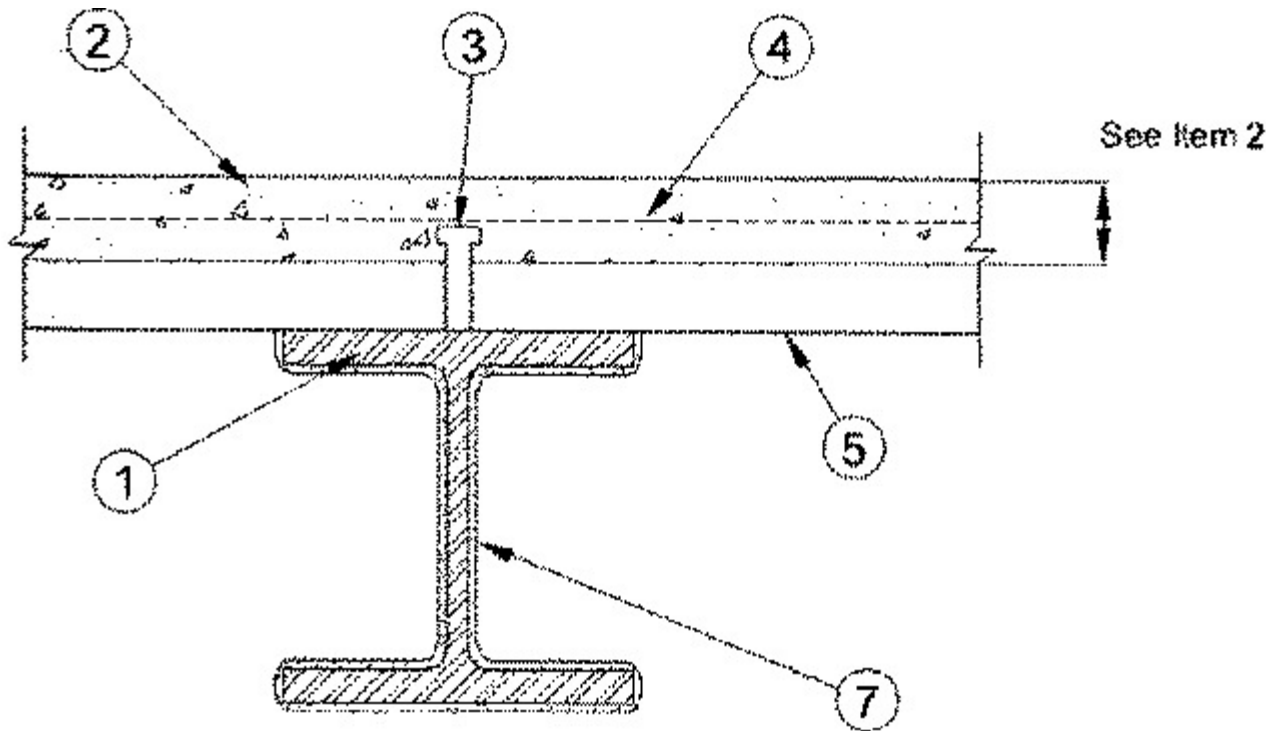

1. **Steel Beams** — Any wide flange steel size shown in the table in Item 7. Beams shall be primed with a two Component Epoxy or Phenolic Modified Alkyd applied at 0.002 in. dry film thickness.

2. **Normal Weight or Lightweight Concrete** — Normal weight concrete, carbonate or siliceous aggregate, 145 lb/ft plus or minus 3 lb/ft weight, 3000 psi compressive strength, vibrated. Lightweight concrete, expanded shale, clay or slate aggregate by rotary-kiln method, 107-120 lb/ft weight, 3000 psi compressive strength, vibrated, 4 to 7 percent entrained air. Min thickness shown in the table below:

Restrained Assembly Rating Hr	Concrete (Type)	Concrete Unit Weight pcf	Concrete Thkns In.
2	Normal Weight	147-153	4-1/2
2	Lightweight	107-113	3-1/4
2	Lightweight	107-116	3-1/4*
2	Lightweight	114-120	3-1/2

*For use with 2 or 3 in. steel floor and form units only.

3. **Shear Connectors (Optional)** — Studs, 3/4 in. diam by 4-1/2 in. long, headed type or equivalent per AISC specification. Welded to the top flange of the beam, through the deck.

4. **Welded Wire Fabric** — 6x6 — W1.4xW1.4.

5. **Steel Floor and Form Units*** — Composite 1-1/2, 2, or 3 in. deep galv Units. Fluted units may be uncoated. Min gauges 22 MSG for fluted and 20/20 MSG for cellular. Any combination of fluted and cellular units may be used. Spacing of welds attaching units to supports shall be 12 in. OC max unless specified otherwise, adjacent units button-punched or welded together at side joints and, unless specified otherwise for specific unit types, spacing of all side joint fastening systems shall not exceed 36 in. OC.

NEW MILLENNIUM BUILDING SYSTEMS L L C — 24 or 36 in. wide Types 2.0CFD, 3.0CFD, 3.0CFDES; 24, 30 or 36 in. wide Types 1.5CFD. Fluted units may be uncoated, phos/painted or galvanized.

VULCRAFT, DIV OF NUCOR CORP — 24, 30 or 36 in. wide Type 1.5VLI, 1.5VLP; 24 or 36 in. wide Types 2VLI, 3VLI, 2VLP, 3VLP. Types 1.5VLI, 2VLI, 3VLI units may be phos/ptd; 24 or 36 in. wide Types 2VLJ, 3VLJ units (+) may be used for max 2 hr. Restrained Assembly.

(+)Side joints of Type 2VLJ or 3VLJ units may be fastened together with No. 8-3/4 in. long self-drilling Tek screws driven diagonally from the top side through the joint of the units at 36 in. OC max.

6. **Joint Cover** — (Not Shown) —2 in. wide pressure sensitive cloth tape.

7. **Mastic & Intumescent Coating*** — Coating spray, brush or trowel applied directly from containers to desired thickness. See table below for appropriate final dry thickness. Flutes above beam to be completely filled with mineral wool insulation having a minimum density of 6 lb/ft³. Thickness shown does not include primer thickness.

	W/D	Hp/A	2 Hr Restrained Assembly 1 Hr Unrestrained Beam (inches)
W18x35	0.67	200	0.076
W6x16	0.67	200	0.076
W8x21	0.67	200	0.076
W6x20	0.68	197	0.076
W12x30	0.69	194	0.075
W10x26	0.70	191	0.075
W16x36	0.70	191	0.075
W8x24	0.70	191	0.075
W14x34	0.72	186	0.074
W21x44	0.74	181	0.074
W18x40	0.76	176	0.073
W16x40	0.77	174	0.073
W5x19	0.78	172	0.072
W10x33	0.79	170	0.072
W12x35	0.80	168	0.072
W8x31	0.80	168	0.072
W10x30	0.81	165	0.072
W14x38	0.81	165	0.072
W8x28	0.81	165	0.072
W24x55	0.83	161	0.071
W21x50	0.84	160	0.071

W6x25	0.84	160	0.071
W12x40	0.86	156	0.070
W14x43	0.87	154	0.070
W16x45	0.87	154	0.070
W18x46	0.87	154	0.070
W18x50	0.88	152	0.069
W8x35	0.90	149	0.069
W10x39	0.92	146	0.068
W24x62	0.93	144	0.068
W24x68	0.94	143	0.067
W21x57	0.95	141	0.067
W21x62	0.95	141	0.067
W14x48	0.96	140	0.067
W16x50	0.96	140	0.067
W18x55	0.96	140	0.067
W12x45	0.97	138	0.066
W10x49	1.01	133	0.065
W12x53	1.01	133	0.065
W8x40	1.02	131	0.065
W27x84	1.03	130	0.065
W18x60	1.04	129	0.064
W21x68	1.04	129	0.064
W24x76	1.04	129	0.064
W10x45	1.05	128	0.064
W14x53	1.05	128	0.064
W12x50	1.07	125	0.063
W16x57	1.08	124	0.063
W16x67	1.08	124	0.063
W14x61	1.09	123	0.063
W12x58	1.10	122	0.062

W10x54	1.11	121	0.062
W12x65	1.11	121	0.062
W21x73	1.11	121	0.062
W18x65	1.12	120	0.062
W18x76	1.12	120	0.062
W30x99	1.12	120	0.062
W24x84	1.14	118	0.061
W27x94	1.15	117	0.061
W8x48	1.20	112	0.059
W14x68	1.21	111	0.059
W30x108	1.21	111	0.059
W33x118	1.21	111	0.059
W18x71	1.22	110	0.059
W10x60	1.23	109	0.058
W12x72	1.23	109	0.058
W24x104	1.23	109	0.058
W16x77	1.24	108	0.058
W27x102	1.24	108	0.058
W18x86	1.26	106	0.057
W21x83	1.26	106	0.057
W24x94	1.27	106	0.057
W14x90	1.29	104	0.056
W36x135	1.29	104	0.056
W21x101	1.30	103	0.056
W30x116	1.30	103	0.056
W14x74	1.31	102	0.056
W33x130	1.32	102	0.056
W12x79	1.34	100	0.055
W10x68	1.38	97	0.054
W24x117	1.38	97	0.054

W27x114	1.38	97	0.054
W30x124	1.38	97	0.054
W21x93	1.40	96	0.053
W18x97	1.41	95	0.053
W14x99	1.42	94	0.052
W16x89	1.42	94	0.052
W21x111	1.42	94	0.052
W33x141	1.43	94	0.052
W36x150	1.43	94	0.052
W8x58	1.43	94	0.052
W14x82	1.44	93	0.052
W12x87	1.46	92	0.051
W30x132	1.47	91	0.051
W36x160	1.52	88	0.049
W18x106	1.53	88	0.049
W24x131	1.53	88	0.049
W33x152	1.53	88	0.049
W10x77	1.55	86	0.048
W14x109	1.55	86	0.048
W21x122	1.55	86	0.048
W27x146	1.55	86	0.048
W16x100	1.58	85	0.047
W12x96	1.61	83	0.046
W36x170	1.61	83	0.046
W8x67	1.63	82	0.046
W21x132	1.67	80	0.045
W30x173	1.67	80	0.045
W14x120	1.69	79	0.044
W24x146	1.70	79	0.044
W27x161	1.70	79	0.044

W18x119	1.71	78	0.043
W36x182	1.71	78	0.043
W10x88	1.75	77	0.042

CARBOLINE CO — TYPE THERMO-SORB, THERMO-SORB VOC.

Investigated for Interior Conditioned Space and Interior General Purpose.

8. **Top Coat** — (Not Shown) - No topcoat required for Interior Conditioned Space. Finishing topcoat for Interior General Purpose, Types Carboguard 893 SG or Santile 655 applied at 0.006 in. dry film thickness or Carbocrylic 3350 or Carbocoat 30R applied at 0.003 in. dry film thickness.

*** Indicates such products shall bear the UL or cUL Certification Mark for jurisdictions employing the UL or cUL Certification (such as Canada), respectively.**

Last Updated on 2019-08-27

The appearance of a company's name or product in this database does not in itself assure that products so identified have been manufactured under UL's Follow-Up Service. Only those products bearing the UL Mark should be considered to be Certified and covered under UL's Follow-Up Service. Always look for the Mark on the product.

UL permits the reproduction of the material contained in the Online Certification Directory subject to the following conditions: 1. The Guide Information, Assemblies, Constructions, Designs, Systems, and/or Certifications (files) must be presented in their entirety and in a non-misleading manner, without any manipulation of the data (or drawings). 2. The statement "Reprinted from the Online Certifications Directory with permission from UL" must appear adjacent to the extracted material. In addition, the reprinted material must include a copyright notice in the following format: "© 2020 UL LLC"